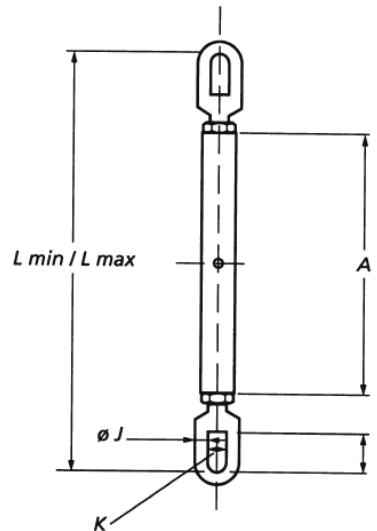

Turnbuckles TR series

oval eye - oval eye

Turnbuckles with trapezoid thread

Stock No.	WLL (t)	L min (mm)	L max (mm)	Take-up (mm)	Thread (trap.)	Dimensions (mm)				Weight (kg)
						A	J	K	L	
41.001.00.22	1	398	566	168	18 x 4	220	12	21	48	1.5
41.001.60.22	1.6	450	638	188	22 x 5	240	16	26	58	2
41.002.00.22	2	470	670	200	24 x 5	260	16	26	58	3
41.002.50.22	2.5	538	754	216	28 x 5	280	20	32	72	5
41.003.10.22	3.1	558	786	228	30 x 6	300	20	32	72	7
41.004.00.22	4	635	876	241	32 x 6	320	25	40	94	9
41.005.00.22	5	658	898	240	36 x 6	340	25	40	94	13
41.006.30.22	6.3	753	1016	263	44 x 7	380	30	45	108	19
41.008.00.22	8	813	1110	297	48 x 8	420	32	50	115	27
41.010.00.22	10	891	1200	309	52 x 8	460	36	60	125	35
41.012.60.22	12.6	988	1328	340	55 x 9	500	40	65	144	46
41.016.00.22	16	1092	1446	354	65 x 10	540	45	70	163	64
41.020.00.22	20	1184	1566	382	70 x 10	580	55	75	173	78
41.025.00.22	25	1270	1674	404	75 x 10	620	60	80	192	90
41.031.50.22	31.5	1382	1812	430	80 x 10	660	60	90	216	130

Minimum Ultimate Strength = 5 x WLL.

Standard painted blue, but can be supplied in any color or galvanized.

Available in all combinations of eyes, stud eyes and welding ends. Factory supplied with lock nuts.

Lock plates or special locking devices possible. Can be supplied with turning wheel or ratchet. Other sizes possible.

Straight or in-line pull only.