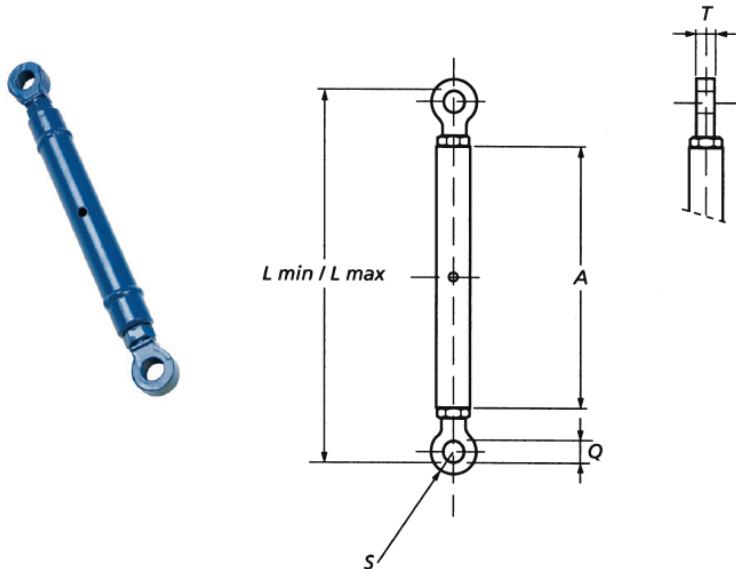

Turnbuckles TR series
stud eye-stud eye

Turnbuckles with trapezoid thread

Stock No.	WLL (t)	L min (mm)	L max (mm)	Take-up (mm)	Thread (trap.)	Dimensions (mm)				Weight (kg)
						A	Q	S	T	
41.001.00.33	1	312	480	168	18 x 4	220	18	17.5	16	1.5
41.001.60.33	1.6	349	537	188	22 x 5	240	23	22.5	20	2
41.002.00.33	2	377	577	200	24 x 5	260	25	25	22	3
41.002.50.33	2.5	411	617	206	28 x 5	280	27	27.5	25	5
41.003.10.33	3.1	438	666	228	30 x 6	300	30	30	28	6
41.004.00.33	4	472	713	241	32 x 6	320	33	32.5	30	8
41.005.00.33	5	511	751	240	36 x 6	340	39	37.5	35	11
41.006.30.33	6.3	577	840	263	44 x 7	380	42	42.5	40	15
41.008.00.33	8	635	932	297	48 x 8	420	48	47.5	45	23
41.010.00.33	10	703	1012	309	52 x 8	460	52	55	50	30
41.012.60.33	12.6	762	1102	340	55 x 9	500	56	60	55	40
41.016.00.33	16	839	1193	354	65 x 10	540	65	65	60	55
41.020.00.33	20	904	1286	382	70 x 10	580	74	70	65	69
41.025.00.33	25	968	1372	404	75 x 10	620	78	75	70	78
41.031.50.33	31.5	1040	1470	430	80 x 10	660	86	85	80	113
41.040.00.33	40	1186	1681	495	90 x 10	695	96	95	90	136
41.050.00.33	50	1286	1836	550	100 x 10	770	106	105	100	160
41.063.00.33	63	1406	2011	605	110 x 10	845	116	115	110	220
41.080.00.33	80	1541	2201	660	120 x 10	920	131	135	125	280
41.100.00.33	100	1662	2377	715	130 x 10	995	146	148	140	370
41.125.00.33	125	1804	2574	770	140 x 10	1070	168	168	160	500
41.160.00.33	160	2028	2908	880	160 x 10	1220	188	190	180	725

Minimum Ultimate Strength = 5 x WLL.

Standard painted blue, but can be supplied in any color or galvanized.

Available in all combinations of eyes, stud eyes and welding ends. Factory supplied with lock nuts.

Lock plates or special locking devices possible. Can be supplied with turning wheel or ratchet. Other sizes possible.

Straight or in-line pull only.