

## PKC - COMPREHENSIVE HYDRAULIC PULLER KITS



Capacities from 10 to 50 tonnes

Combination of 4 different pullers in one set

Quick set-up time, easy to use

The PKC heavy duty, multi-purpose hydraulic puller kit range is extremely versatile and includes 2-way and 3-way grip pullers (as detailed on page 72), bearing pullers, bearing cup pullers and cross head pullers. All models are designed for pulling, pushing, installing and removing all press fitted or heat fitted parts such as gears, bearings, sleeves, cogs, internal bearings, wheels, sprockets, flywheels, etc. The range offers a selection of 4 models with pulling capacities up to 50 tonnes, all supplied complete with a full set of versatile, detachable hydraulic components.

- >> Working pressure 700 Bar
- >> Complete hydraulic system supplied, including gauge
- >> High quality, drop-forged steel components
- >> Supplied complete with carrying case

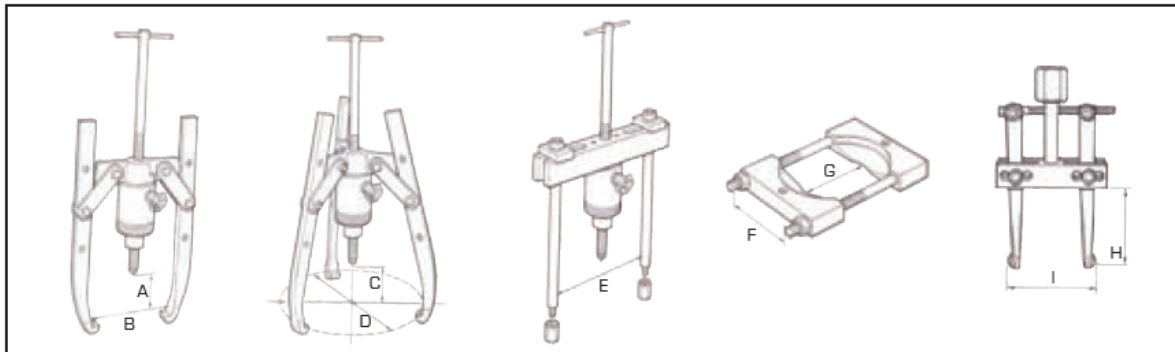

Model number	Capacity tonnes	Cylinder model no.	Pump model no.	Weight kg
<b>PKC10</b>	10	HHS102	HP110	25
<b>PKC20</b>	20	HHS202	HP110	60
<b>PKC30</b>	30	HHS302	HP110	116
<b>PKC50</b>	50	HHS603	HP227	268

Dimensions in mm											
A	B	C	D	E		F	G		H	I	
Reach	Dia	Reach	Dia	Min	Max		Min	Max		Min	Max
220	300	200	475	115	250	110	10	105	115	38	153
205	408	305	508	135	325	152	13	130	135	38	153
363	660	528	865	200	413	260	35	250	148	38	180
422	915	732	1118	230	546	300	31	330	147	76	230

Dimensions A, B, C & D calculated with 15° outward angled puller legs.