

## HFS - HYDRAULIC FLANGE SPREADERS



Capacities from 4.5 to 10 tonnes

Working pressure 700 Bar

Supplied in a steel storage & carrying case

HFS hydraulic flange spreaders provide the ideal solution for safely opening pipe flanges in the marine and oil & gas industry. Available in capacities from 0 - 4.5 tonnes and 0 - 10 tonnes, both models offer the user the capability of opening flanges up to 92mm thick. Operated with a standard Hi-Force hydraulic pump (full specifications see page 23) and connecting hose (see page 36) and supplied in a handy steel storage and carrying case, Hi-Force hydraulic flange spreaders can be operated individually, or as a pair when opening large flanges. With Hi-Force flange spreaders you are only minutes away from safely opening the toughest flanges without the risk of sparks caused by hammer blows, chisels and flying wedges.

- >> Supplied complete with manually operated pump and hose assembly
- >> Optional wedge available for larger separation
- >> Suitable for stud bolt sizes up to 41 mm

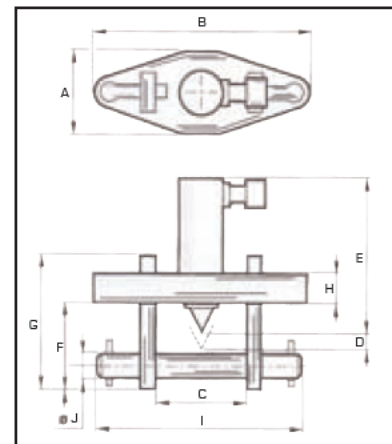
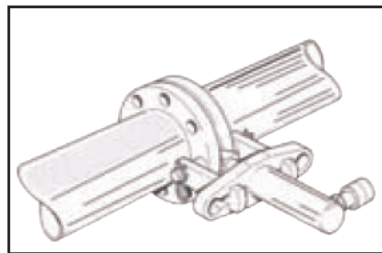

Specifications :

Model number	Capacity tonnes	Stroke mm	Oil capacity cm <sup>3</sup>	Max. flange thickness mm	Stud size mm	Standard wedge mm	Optional wedge mm	Weight kg
<b>HFS50</b>	4.5	75	48	2 x 57	19 - 29	3 - 29	30 - 56	22.5
<b>HFS100</b>	10	56	81	2 x 92	32 - 41	3 - 29	30 - 56	29.1

**Note:** HFS flange spreaders are also available as spreader only (without pump and hose assembly). Please add suffix 'H' to model number if spreader only is required.

Dimensions in mm :

Model number	A	B	C min	C max	D	E	F	G	H	I	J
<b>HFS50</b>	76	210	61	155	10	192	69	129	25	206	18
<b>HFS100</b>	108	290	61	224	30	165	89	178	38	273	31