

DSP

DOUBLE SWIVEL LIFTING POINT
POINT DE LEVAGE À DOUBLE ARTICULATION
DOPPELWIRBEL-ANSCHLAGPUNKT
CÁNCAMO DOBLE ARTICULADO



HIGH TENSILE ■ HAUTE RESISTANCE ■ HOCHFEST ■ ALTA RESISTENCIA

Class > 8

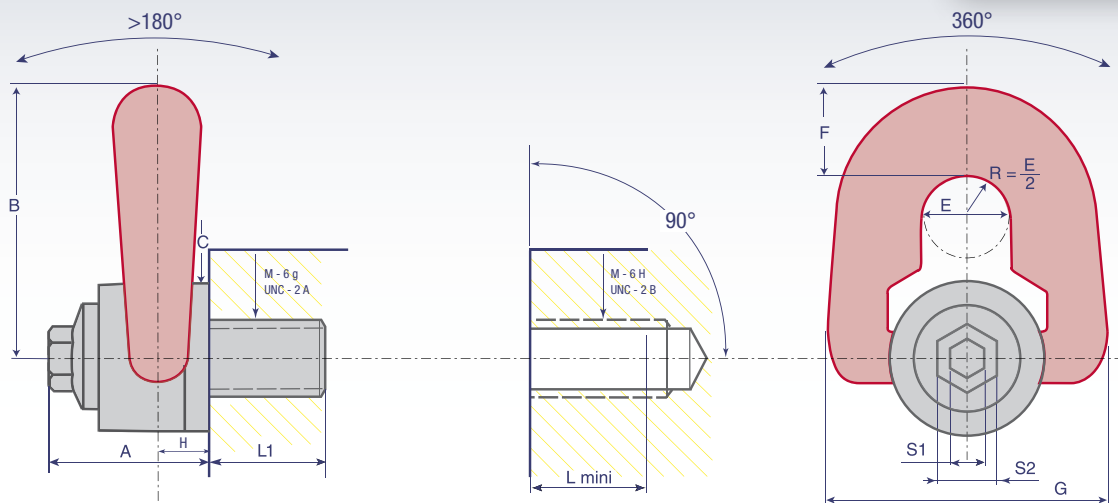

www.codipro.net

1,000 LBS = 0,4536 TO

Reference Référence Referenz Referencia	WLL CMU Höchstbelastung CMU	Safety factor Coef. sécurité Sicherheitsfaktor Coef. seguridad	Diamètre Diamètre Durchmesser Diámetro	Ø	P	standard L1	N.m FootLBS	S1	S2	A	B	C	E	F	G	H	Weight Poids Gewicht Peso
DSP M 8	0,3 TO	5	M8 (x1,25)			14	6	8	16	33	56	30	19	19	58	9,5	0,3 Kg
DSP M 10	0,6 TO	5	M10 (x1,50)			17	10	8	16	33	56	30	19	19	58	9,5	0,3 Kg
DSP M 12	1 TO	5	M12 (x1,75)			21	15	8	16	33	56	30	19	19	58	9,5	0,3 Kg
DSP M 14	1,3 TO	5	M14 (x2)			23	30	8	20	45	76	45	25	27	79	13	0,9 Kg
DSP M 16	1,6 TO	5	M16 (x2)			27	50	8	20	45	76	45	25	27	79	13	0,9 Kg
DSP M 18	2 TO	5	M18 (x2,5)			27	70	8	20	45	76	45	25	27	79	13	1 Kg
DSP M 20	2,5 TO	5	M20 (x2,5)			30	100	8	20	45	76	45	25	27	79	13	1 Kg
DSP U 516	650 LBS	5	UNC 5/16"-18			15	7 _{FL}	5/16"	5/8"	33	56	30	19	19	58	9,5	0,3 Kg
DSP U 038	1,200 LBS	5	UNC 3/8"-16			17	8 _{FL}	5/16"	5/8"	33	56	30	19	19	58	9,5	0,3 Kg
DSP U 050	2,200 LBS	5	UNC 1/2"-13			21	12 _{FL}	5/16"	5/8"	33	56	30	19	19	58	9,5	0,3 Kg
DSP U 058	3,800 LBS	5	UNC 5/8"-11			27	40 _{FL}	5/16"	20	45	76	45	25	27	79	13	1 Kg
DSP U 075	5,500 LBS	5	UNC 3/4"-10			30	80 _{FL}	5/16"	20	45	76	45	25	27	79	13	1 Kg

Other variants of the fixing axis available upon request / Autres variantes de l'axe de fixation sur demande / Weitere Varianten der Verbindungsbolzen auf Anfrage / Otras variantes del eje de fijación bajo solicitud



www.codipro.net ■ info@codipro.net

Luxembourg : Zone d'Activités Salzbaach ■ L - 9559 WILTZ ■ BP 100 L - 9502 WILTZ ■ Tél. +352 26 81 54-1 ■ Fax +352 81 05 17

France : 9, Boulevard des Ravalières Z.A. ■ F - 72560 CHANGÉ ■ Tél. +33(0)2 43 40 17 00 ■ Fax +33(0)2 43 40 07 99