

FIXED POINT CLAMP

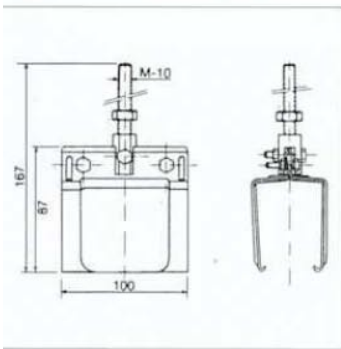

Ref. PF-4

Necessary to avoid total movement of the system and for allowing free expansion to both ends.

- It is recommended that they are installed in the centre of the system.

- In galvanized steel.

- Weight: 400 grms.

For outdoor systems or aggressive environments, with epoxy treatment and screws made of stainless steel. Ref. PF-4E.



Ref. PF-4